

**DEEPPSEA**  
Power & Light®



# Low-Light SeaCam®



## Operator's Manual

T: (858) 576-1261  
F: (858) 576-0219

4033 Ruffin Road  
San Diego, CA  
92123- 1817 USA

[www.deepsea.com](http://www.deepsea.com)  
[sales@deepsea.com](mailto:sales@deepsea.com)



# Specification Overview

LLSC-3085	
<b>Mechanical Specifications</b>	
<b>Housing</b>	Aluminum Titanium
<b>Port</b>	Optically Polished Glass Hemisphere
<b>Outer Diameter (w/o crash gaurd)</b>	56 mm [2.20 in]
<b>Overall Length (w/o connector)</b>	124 mm [4.88 in]
<b>Weight in Air</b>	Titanium: 0.56 kg [1.23 lbs]
<b>Weight in Water</b>	Titanium: 0.30 kg [0.66 lbs]
<b>Environmental Specifications</b>	
<b>Depth Rating</b>	Aluminum: 4,000 m [13,123 ft] Titanium: 6,000 meters [19,685 ft]
<b>Operating Temp.</b>	-10° C to 50° C [14° F to 122° F]
<b>Storage Temp.</b>	-30° C to 70° C [-22° F to 158° F]
<b>Optical Specifications</b>	
<b>Lens</b>	3.0mm, F/1.0
<b>Focus</b>	Fixed Focus
<b>FOV in Water</b>	85° H x 62° V x 110° D
<b>Video Specifications</b>	
<b>Image Sensor</b>	1/3-inch CCD image sensor with Global Shutter
<b>Resolution</b>	470 TV lines horizontal
<b>Scene Illumination</b>	0.0016 Lux [50 IRE]
<b>Faceplate Illumination</b>	0.00045 Lux [50 IRE]
<b>Signal to Noise</b>	>50 dB
<b>Video Output</b>	Composite, 1.0 V p-p into 75 ohm, Unbalanced
<b>Video Format</b>	EIA or CCIR
<b>Electrical Specifications</b>	
<b>Voltage</b>	9~36 VDC
<b>Power</b>	2W max

\*Measured values using example product in water.

## Standard Connector

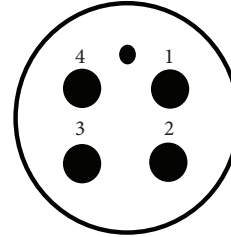

### BH4MP/MCBH4MP

- 1 = DC-
- 2 = DC+
- 3 = Video
- 4 = N/C

Other connector options available upon request.

## Dimensions

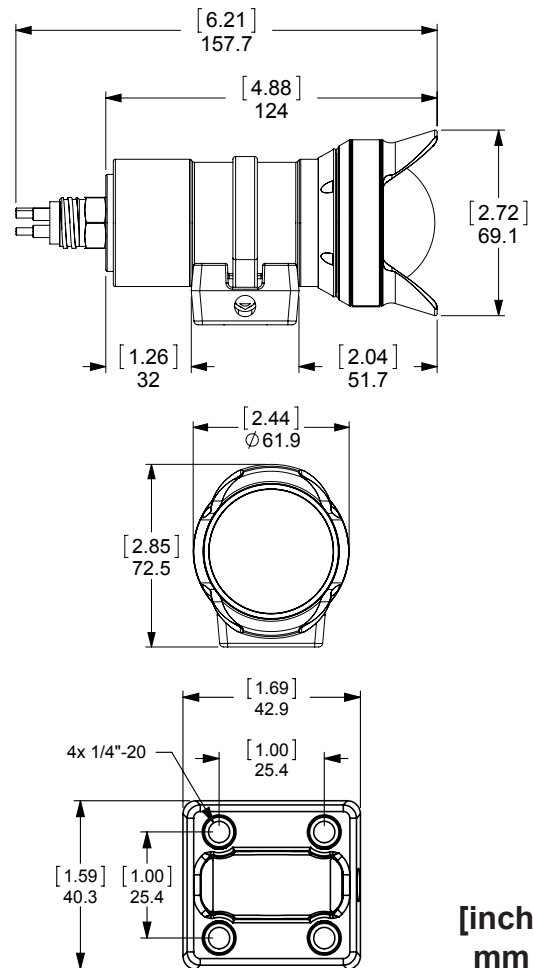

[inch]  
mm

# Table of Contents

Specification Overview.....	2
Table of Contents .....	3
Safety Symbols .....	4
General Notes and Warnings.....	4
Pre & Post Dive Inspection.....	4
Operation Instructions.....	4-5
Flooding Repair Procedure .....	5
Troubleshooting .....	5
RMA Procedure for Repair .....	5-6
Warranty Information .....	6

## Safety Symbol

In this operator's manual and on the product, safety symbols are used to communicate important safety information. This section is provided to improve understanding of these symbols.



This is the safety alert symbol. It is used to alert you to potential personal injury hazards. Obey all safety messages that follow this symbol to avoid possible injury or death.



**DANGER** indicates a hazardous situation which, if not avoided, could result in death or serious injury.



**WARNING** indicates a hazardous situation which, if not avoided, could result in damage to the product or bodily harm.



**CAUTION** indicates a hazardous situation which, if not avoided, could result in minor or moderate injury.



**NOTICE** indicates information that relates to the protection of property.



This symbol means read the operator's manual carefully before using the equipment. The operator's manual contains important information on the safe and proper operation of the equipment.



This symbol means always wear safety glasses with side shields or goggles when handling or using this equipment to reduce the risk of eye injury.



This symbol indicates the risk of electrical shock.

## General Notes and

### Warnings

The Low-Light SeaCam supports a variety of connectors and pin-outs. By looking on the camera, the user can see the model, depth rating, video format as well as the pin out orientation. Be sure to verify the pin-out before use.

It is very important when preparing the system for deployment that the cable, at both the camera and topside ends, be carefully dressed to provide complete strain relief to the connectors. Failure of the strain relief provisions will almost certainly damage the connectors and possibly other elements of the system.



Do not operate any high voltage electrical equipment in or around water without using a Ground Fault Circuit Interrupter circuit (GFCI) and an isolation transformer, especially when divers are in the water.



Never place the camera in a vice or other hard clamping tool. Should it become necessary to hold the camera more tightly than can be managed by hand, use a clean, good quality strap wrench.

### Pre and Post Dive Inspection

Rinse your Low-Light SeaCam in fresh water after use in saltwater.

Always check to make sure that the rear bulkhead connector assembly is secured before deployment.

Before and after each deployment, check the following areas for damage, wear or corrosion:

- Rear bulkhead connector assembly
- Video cable
- Front window
- Retaining Cowl



After each deployment, carefully check to make sure the camera has not flooded. It is possible for the camera to partially flood and then reseal itself while underwater. Upon surfacing, the camera can be

come internally pressurized, which may be potentially dangerous. Additionally, if the power remains on when the camera has partially flooded, it is possible for electrolytic generation of an explosive mixture of hydrogen and oxygen gases. If a camera appears flooded upon removal from the water, it should be treated as potentially dangerous. Point the camera away from persons and valuable equipment and make sure that the power is disconnected. See the Flooding Repair Procedure for more information.

## Operation Instructions

1. Prepare a power supply with 9-36V DC output.
2. Plug the red [positive(+)] and black [negative(-)] banana plugs of the camera cable into their respective jacks on the power supply.
3. Plug the BNC connector on the top side of the cable into the monitor or VCR video-in jack (a BNC-to-RCA adapter may be required by the monitor/VCR in use).
4. Lubricate the camera bulkhead connector with an appropriate silicone lubricant (spray type recommended), and using a linear motion plug the female inline connector into the male bulkhead connector on the back of the camera.
5. Screw the locking sleeves together firmly (hand tight-do not use tools). The camera is now ready for operation; switch the power supply ON to power the camera. The camera draws approximately 2W of power during operation, and will work when supplied between 9-36 volts DC.

## Flooding Repair Procedure



If the camera stops working while underwater, you should assume that it has been flooded. When working on a potentially flooded camera, it is important to use appropriate personal protective equipment to include, at a minimum, eye and hand protection.

1. Immediately turn off the power to the unit.
2. Open the housing by removing the rear end cap-retaining ring. Grasp the rear end cap in one hand and the camera housing in the other. With care, separate the two components using a linear motion. If required gently twist components while separating.
3. Pour out any water trapped in the housing.
4. If the camera is completely flooded, rinse the internal components with clean fresh water in order to minimize contamination and corrosion.
5. Allow parts to dry in air or a convection oven set at 60° C (190° F).

IMPORTANT! DeepSea Power & Light cannot be responsible for any damage incurred during emergency field repairs. Such repairs should be undertaken only as a last resort and by qualified personnel.

## Troubleshooting

1. If the camera stops working while underwater assume that it has been flooded. See [Flooding Repair](#) procedure.
2. Once it has been determined that the camera is not flooded, or if it does not turn on during pre-deployment checks, troubleshoot in the following sequence:
  - a. Check the cable/inline connector to make sure that correct voltage and current are being supplied, and that the correct sockets are being used. See page 2 of this manual for electrical specs and connector pin-outs.
  - b. Remove the connector. Inspect the assembly for visual signs of wear. Use a multi-meter check for continuity or shorts in the connector. Try a spare connector, if available.
  - c. Check the wires that go from the power supply to the camera base for wear. If they appear worn, replace them.
  - d. Check to make sure that the power supply board is securely attached to the camera. If it is loose, check for damage on the board. If there appears to be no damage, reattach the board to the camera. Try using a spare driver board if available.
  - e. If the camera still does not work, return it to DeepSea Power & Light using the RMA Procedure.

## RMA Procedure for Repair

Should it be necessary to return your camera to the factory, follow the procedure for the Flooded Camera Repair above, and by leaving the connector partially unscrewed. For warranty and non-warranty repairs please contact DeepSea Power & Light for a RMA number prior to returning your item. Please have your light model number, serial number and any other pertinent information along with a description of the problem, on hand when you call, or include them in a fax or email. When shipping your item, be sure that the freight is pre-paid (CODs will not be accepted) and that the RMA number is clearly printed on the outside of the box. All shipments should

be sent to the address below:

**DeepSea Power & Light**  
**Attn: RMA #####**  
**4033 Ruffin Road**  
**San Diego, CA 92123-1817**  
**U.S.A**  
**Tel: (858) 576-1261**  
**Fax: 858-576-0219**  
**Email: RMA@deepsea.com**

## Warranty Information

### Limited Warranty

Seller warrants that the goods (except internal electronic components) sold under this contract will be free from defect in material and workmanship for a period of one year from the date of shipment from the factory, if they have been properly used. Internal electronic components are warranted for 90 days from the date of shipment from the factory, if they have been properly used. This warranty will be limited to the repair or replacement of parts and the necessary labor and services required to repair the goods. IT IS EXPRESSLY AGREED THAT THIS WARRANTY WILL BE IN LIEU OF ALL WARRANTIES OF FITNESS AND IN LIEU OF THE WARRANTY OF MERCHANTABILITY. This warranty is the exclusive and only warranty to pass with the goods under this contract. No agent, employee, or representative of the Seller has any authority to bind Seller to any information, representation, or warranty concerning the goods sold under this contract, and unless an affirmation, representation, or warranty made by an agent, employee, or representative is specifically included within this contract, it will not be enforceable by Buyer. If notice of defect is given to DeepSea Power & Light LLC within such 90 day or one year warranty period, the sole obligation of DeepSea Power & Light LLC shall be to furnish new or repaired parts free of charge in exchange for parts which have been proved defective and does not include any other costs such as the cost of removal of the defective part, installation, labor, or consequential damages of any kind, the exclusive remedy being to require DeepSea Power & Light LLC to furnish such new parts. Under no circumstances shall the Buyer be entitled to recover any incidental damages as that term is defined in Commercial Code §2715.



T: (858) 576-1261  
F: (858) 576-0219

www.deepsea.com  
sales@deepsea.com

